

# DEEPGROOVE®

U.S. Patent No. 5,638,728

## Internal Grooving Tools

- For diameters 1" and larger
- 3/4" and 1" shank diameter
- Right hand orientation standard



Now Available in 4 styles!

- Long Standard Neck
- Long Heavy Duty Neck
- Short Standard Neck
- Short Heavy Duty Neck

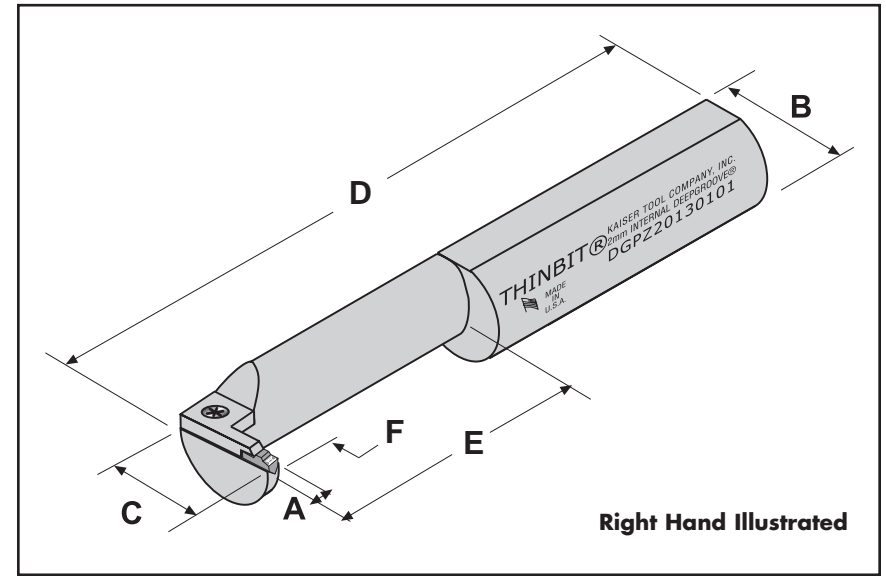
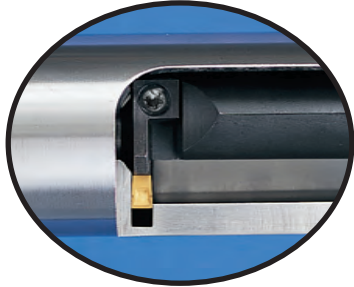

U.S. Patent No. 5,638,728

### Long Standard Neck

| SPECIFICATIONS |              |                |              |             |                | ORDER CODE                                               |                                       |                   |                       |       |        |                |          |
|----------------|--------------|----------------|--------------|-------------|----------------|----------------------------------------------------------|---------------------------------------|-------------------|-----------------------|-------|--------|----------------|----------|
| Minimum Bore   | Insert Width | Shank Diameter | Depth of Cut | Neck Length | Overall Length | Toolholder Package<br>Includes Shank, Clamp and Hardware | Inserts<br>Use Inserts Beginning With | Replacement Parts |                       |       |        |                |          |
| 'C'            | 'A'          | 'B'            | 'F'          | 'E'         | 'D'            |                                                          |                                       | Shank             | Clamp                 | Screw | Wrench |                |          |
| 1"             | 2mm (.078")  | 3/4"           | .500"        | 3"          | 7"             | DGPZ2013013430                                           | 'DGI2'<br>(Page 6-1)                  | DGT20130134R30    | DGC82013              | S7352 | W4010  |                |          |
|                |              | 1"             |              |             |                |                                                          |                                       | DGT20130101R30    | DGC82013              |       |        |                |          |
|                | 3mm (.118")  | 3/4"           |              |             |                |                                                          |                                       | DGPZ3013013430    | 'DGMi3'<br>(Page 6-1) |       |        | DGT30130134R30 | DGC83013 |
|                |              | 1"             |              |             |                |                                                          |                                       | DGPZ3013010130    | 'DGMi3'<br>(Page 6-1) |       |        | DGT30130101R30 | DGC83013 |
|                | 4mm (.157")  | 3/4"           |              |             |                |                                                          |                                       | DGPZ4013013430    | 'DGMi4'<br>(Page 6-1) |       |        | DGT40130134R30 | DGC84013 |
|                |              | 1"             |              |             |                |                                                          |                                       | DGPZ4013010130    | 'DGMi4'<br>(Page 6-1) |       |        | DGT40130101R30 | DGC84013 |

### Short Standard Neck

| SPECIFICATIONS |              |                |              |             |                | ORDER CODE                                               |                                       |                   |                       |       |        |                |          |
|----------------|--------------|----------------|--------------|-------------|----------------|----------------------------------------------------------|---------------------------------------|-------------------|-----------------------|-------|--------|----------------|----------|
| Minimum Bore   | Insert Width | Shank Diameter | Depth of Cut | Neck Length | Overall Length | Toolholder Package<br>Includes Shank, Clamp and Hardware | Inserts<br>Use Inserts Beginning With | Replacement Parts |                       |       |        |                |          |
| 'C'            | 'A'          | 'B'            | 'F'          | 'E'         | 'D'            |                                                          |                                       | Shank             | Clamp                 | Screw | Wrench |                |          |
| 1"             | 2mm (.078")  | 3/4"           | .500"        | 1.5"        | 5.5"           | DGPZ2013013415                                           | 'DGI2'<br>(Page 6-1)                  | DGT20130134R15    | DGC82013              | S7352 | W4010  |                |          |
|                |              | 1"             |              |             |                |                                                          |                                       | DGT20130101R15    | DGC82013              |       |        |                |          |
|                | 3mm (.118")  | 3/4"           |              |             |                |                                                          |                                       | DGPZ3013013415    | 'DGMi3'<br>(Page 6-1) |       |        | DGT30130134R15 | DGC83013 |
|                |              | 1"             |              |             |                |                                                          |                                       | DGPZ3013010115    | 'DGMi3'<br>(Page 6-1) |       |        | DGT30130101R15 | DGC83013 |
|                | 4mm (.157")  | 3/4"           |              |             |                |                                                          |                                       | DGPZ4013013415    | 'DGMi4'<br>(Page 6-1) |       |        | DGT40130134R15 | DGC84013 |
|                |              | 1"             |              |             |                |                                                          |                                       | DGPZ4013010115    | 'DGMi4'<br>(Page 6-1) |       |        | DGT40130101R15 | DGC84013 |

### Long Heavy Duty Neck

| SPECIFICATIONS |              |                |              |             |                | ORDER CODE                                               |                                       |                   |                       |       |        |                |          |
|----------------|--------------|----------------|--------------|-------------|----------------|----------------------------------------------------------|---------------------------------------|-------------------|-----------------------|-------|--------|----------------|----------|
| Minimum Bore   | Insert Width | Shank Diameter | Depth of Cut | Neck Length | Overall Length | Toolholder Package<br>Includes Shank, Clamp and Hardware | Inserts<br>Use Inserts Beginning With | Replacement Parts |                       |       |        |                |          |
| 'C'            | 'A'          | 'B'            | 'F'          | 'E'         | 'D'            |                                                          |                                       | Shank             | Clamp                 | Screw | Wrench |                |          |
| 1"             | 2mm (.078")  | 3/4"           | .393"        | 3"          | 7"             | DGPZ2010013430                                           | 'DGI2'<br>(Page 6-1)                  | DGT20100134R30    | DGC82013              | S7352 | W4010  |                |          |
|                |              | 1"             |              |             |                |                                                          |                                       | DGT20100101R30    | DGC82013              |       |        |                |          |
|                | 3mm (.118")  | 3/4"           |              |             |                |                                                          |                                       | DGPZ3010013430    | 'DGMi3'<br>(Page 6-1) |       |        | DGT30100134R30 | DGC83013 |
|                |              | 1"             |              |             |                |                                                          |                                       | DGPZ3010010130    | 'DGMi3'<br>(Page 6-1) |       |        | DGT30100101R30 | DGC83013 |
|                | 4mm (.157")  | 3/4"           |              |             |                |                                                          |                                       | DGPZ4010013430    | 'DGMi4'<br>(Page 6-1) |       |        | DGT40100134R30 | DGC84013 |
|                |              | 1"             |              |             |                |                                                          |                                       | DGPZ4010010130    | 'DGMi4'<br>(Page 6-1) |       |        | DGT40100101R30 | DGC84013 |

### Short Heavy Duty Neck

| SPECIFICATIONS |              |                |              |             |                | ORDER CODE                                               |                                       |                   |                       |       |        |                |          |
|----------------|--------------|----------------|--------------|-------------|----------------|----------------------------------------------------------|---------------------------------------|-------------------|-----------------------|-------|--------|----------------|----------|
| Minimum Bore   | Insert Width | Shank Diameter | Depth of Cut | Neck Length | Overall Length | Toolholder Package<br>Includes Shank, Clamp and Hardware | Inserts<br>Use Inserts Beginning With | Replacement Parts |                       |       |        |                |          |
| 'C'            | 'A'          | 'B'            | 'F'          | 'E'         | 'D'            |                                                          |                                       | Shank             | Clamp                 | Screw | Wrench |                |          |
| 1"             | 2mm (.078")  | 3/4"           | .393"        | 1.5"        | 5.5"           | DGPZ2010013415                                           | 'DGI2'<br>(Page 6-1)                  | DGT20100134R15    | DGC82013              | S7352 | W4010  |                |          |
|                |              | 1"             |              |             |                |                                                          |                                       | DGT20100101R15    | DGC82013              |       |        |                |          |
|                | 3mm (.118")  | 3/4"           |              |             |                |                                                          |                                       | DGPZ3010013415    | 'DGMi3'<br>(Page 6-1) |       |        | DGT30100134R15 | DGC83013 |
|                |              | 1"             |              |             |                |                                                          |                                       | DGPZ3010010115    | 'DGMi3'<br>(Page 6-1) |       |        | DGT30100101R15 | DGC83013 |
|                | 4mm (.157")  | 3/4"           |              |             |                |                                                          |                                       | DGPZ4010013415    | 'DGMi4'<br>(Page 6-1) |       |        | DGT40100134R15 | DGC84013 |
|                |              | 1"             |              |             |                |                                                          |                                       | DGPZ4010010115    | 'DGMi4'<br>(Page 6-1) |       |        | DGT40100101R15 | DGC84013 |