

**PRODUCT INFORMATION**

- 2, 3, 4, 5 and 6mm insert widths.
- Recessed pocket and raised edge for chip control.
- Internal grooving, external grooving, face grooving and parting.
- Sub-micron grain **DURA-MAX® 2000** carbide.
- Inserts available with TiN, TiAlN, TiCN and Diamond coating.

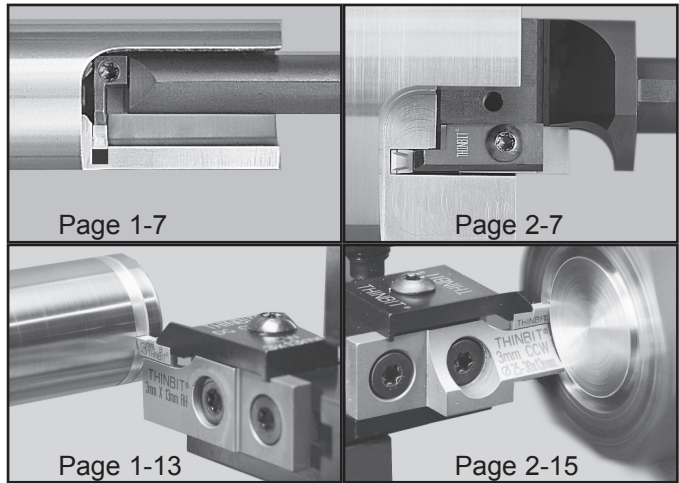

**INSERT GEOMETRY**

<p><b>SHARP CORNER (TOP VIEW)</b></p>	<p><b>CORNER RADIUS (TOP VIEW)</b></p>	<p><b>FULL RADIUS (TOP VIEW)</b></p>	<p><b>60° THREADING (TOP VIEW)</b></p>
<p><b>7° LEAD ANGLE (TOP VIEW)</b></p> <p>Right Hand    Left Hand</p>	<p><b>15°(+) TOP RAKE (SIDE VIEW)</b></p>	<p><b>15° (-) TOP RAKE (SIDE VIEW)</b></p>	<p><b>90° CHAMFERING (TOP VIEW)</b></p>

<b>TECHNICAL SECTIONS</b>	<b>PRODUCT DEMONSTRATION</b>	<b>SPEEDS AND FEEDS</b>	<b>APPLICATION REFERENCE</b>	<b>TROUBLESHOOTING</b>
	<p><a href="http://www.thinbit.com/qr6-1">www.thinbit.com/qr6-1</a></p>	<p>PGS 9-10, 9-12, 9-18 &amp; 9-20</p>	<p>PGS 9-3 &amp; 9-4</p>	<p>PG 9-7</p>

## ORDERING INSTRUCTIONS

Select the **ORDER CODE** in the table at right that represents your selection of insert geometry and coating. Please pay special attention to the '**Compatibility**' column to match the insert with the correct tooling.

The **ORDER CODE** for a 3mm wide, '**DGI**' Style insert with .015" radius and TiN coating is '**DGI30BC**'

### KAISER TOOL COMPANY, INC.

# 'DGI' & 'DGMI' STYLE OD/ID AND FACE GROOVING INSERTS

SPECIFICATIONS			ORDER CODE						
Insert Width +.005"/ -.000"	Compatibility	Insert Geometry	DURA-MAX® 2000 Carbide See Page 9-10 or 9-12 for Speeds and Feeds						
			Uncoated	TiN	TiCN Non-stock	TiAlN	Diamond Non-stock		
.078" (2mm)	Use in all 2mm 'DGP'	Sharp Corner	DGI20BU1	DGI20BC1	DGI20BD1	DGI20BE1	DGI20BF1		
		.004" (.10mm) radius	DGI20BU2010	DGI20BC2010	DGI20BD2010	DGI20BE2010	DGI20BF2010		
		.008" (.20mm) radius	DGI20BU2020	DGI20BC2020	DGI20BD2020	DGI20BE2020	DGI20BF2020		
		.010" (.25mm) radius	DGI20BU2025	DGI20BC2025	DGI20BD2025	DGI20BE2025	DGI20BF2025		
		.015" (.38mm) radius	DGI20BU	DGI20BC	DGI20BD	DGI20BE	DGI20BF		
		.020" (.50mm) radius	DGI20BU2050	DGI20BC2050	DGI20BD2050	DGI20BE2050	DGI20BF2050		
		.030" (.75mm) radius	DGI20BU2075	DGI20BC2075	DGI20BD2075	DGI20BE2075	DGI20BF2075		
		Full Radius	DGI20BU4	DGI20BC4	DGI20BD4	DGI20BE4	DGI20BF4		
		15° (+) Top Rake	DGI20BU7P	DGI20BC7P	DGI20BD7P	DGI20BE7P	DGI20BF7P		
		15° (-) Top Rake	DGI20BU7N	DGI20BC7N	DGI20BD7N	DGI20BE7N	DGI20BF7N		
		7° R.H. Lead Angle	DGI20BU3R	DGI20BC3R	DGI20BD3R	DGI20BE3R	DGI20BF3R		
		7° L.H. Lead Angle	DGI20BU3L	DGI20BC3L	DGI20BD3L	DGI20BE3L	DGI20BF3L		
		.118" (3mm)	Use ONLY with 3mm 'DGPZ' ID tools and face grooving heads with major diameter codes '02' and '25'	Sharp Corner	DGMI30BU1	DGMI30BC1	DGMI30BD1	DGMI30BE1	DGMI30BF1
				.015" (.38mm) radius	DGMI30BU	DGMI30BC	DGMI30BD	DGMI30BE	DGMI30BF
Use in 3mm 'DGP' for OD grooving/parting and major diameters greater than .984"	Sharp Corner		DGI30BU1	DGI30BC1	DGI30BD1	DGI30BE1	DGI30BF1		
	.004" (.10mm) radius		DGI30BU2010	DGI30BC2010	DGI30BD2010	DGI30BE2010	DGI30BF2010		
	.008" (.20mm) radius		DGI30BU2020	DGI30BC2020	DGI30BD2020	DGI30BE2020	DGI30BF2020		
	.010" (.25mm) radius		DGI30BU2025	DGI30BC2025	DGI30BD2025	DGI30BE2025	DGI30BF2025		
	.015" (.38mm) radius		DGI30BU	DGI30BC	DGI30BD	DGI30BE	DGI30BF		
	.020" (.50mm) radius		DGI30BU2050	DGI30BC2050	DGI30BD2050	DGI30BE2050	DGI30BF2050		
	.030" (.75mm) radius		DGI30BU2075	DGI30BC2075	DGI30BD2075	DGI30BE2075	DGI30BF2075		
	.040" (1.0mm) radius		DGI30BU2100	DGI30BC2100	DGI30BD2100	DGI30BE2100	DGI30BF2100		
	Full Radius		DGI30BU4	DGI30BC4	DGI30BD4	DGI30BE4	DGI30BF4		
	15° (+) Top Rake		DGI30BU7P	DGI30BC7P	DGI30BD7P	DGI30BE7P	DGI30BF7P		
	15° (-) Top Rake		DGI30BU7N	DGI30BC7N	DGI30BD7N	DGI30BE7N	DGI30BF7N		
	7° R.H. Lead Angle		DGI30BU3R	DGI30BC3R	DGI30BD3R	DGI30BE3R	DGI30BF3R		
	7° L.H. Lead Angle		DGI30BU3L	DGI30BC3L	DGI30BD3L	DGI30BE3L	DGI30BF3L		
	60° Threading		DGI30BU5	DGI30BC5	DGI30BD5	DGI30BE5	DGI30BF5		
	90° Chamfering		DGI30BU6	DGI30BC6	DGI30BD6	DGI30BE6	DGI30BF6		
	.157" (4mm)		Use ONLY with 4mm 'DGPZ' ID tools and face grooving heads with major diameter codes '02' and '25'	Sharp Corner	DGMI40BU1	DGMI40BC1	DGMI40BD1	DGMI40BE1	DGMI40BF1
.015" (.38mm) radius		DGMI40BU		DGMI40BC	DGMI40BD	DGMI40BE	DGMI40BF		
Use in 4mm 'DGP' for OD grooving/parting and major diameters greater than .984"		Sharp Corner	DGI40BU1	DGI40BC1	DGI40BD1	DGI40BE1	DGI40BF1		
		.004" (.10mm) radius	DGI40BU2010	DGI40BC2010	DGI40BD2010	DGI40BE2010	DGI40BF2010		
		.008" (.20mm) radius	DGI40BU2020	DGI40BC2020	DGI40BD2020	DGI40BE2020	DGI40BF2020		
		.010" (.25mm) radius	DGI40BU2025	DGI40BC2025	DGI40BD2025	DGI40BE2025	DGI40BF2025		
		.015" (.38mm) radius	DGI40BU	DGI40BC	DGI40BD	DGI40BE	DGI40BF		
		.020" (.50mm) radius	DGI40BU2050	DGI40BC2050	DGI40BD2050	DGI40BE2050	DGI40BF2050		
		.030" (.75mm) radius	DGI40BU2075	DGI40BC2075	DGI40BD2075	DGI40BE2075	DGI40BF2075		
		.040" (1.0mm) radius	DGI40BU2100	DGI40BC2100	DGI40BD2100	DGI40BE2100	DGI40BF2100		
		Full Radius	DGI40BU4	DGI40BC4	DGI40BD4	DGI40BE4	DGI40BF4		
		15° (+) Top Rake	DGI40BU7P	DGI40BC7P	DGI40BD7P	DGI40BE7P	DGI40BF7P		
		15° (-) Top Rake	DGI40BU7N	DGI40BC7N	DGI40BD7N	DGI40BE7N	DGI40BF7N		
		7° R.H. Lead Angle	DGI40BU3R	DGI40BC3R	DGI40BD3R	DGI40BE3R	DGI40BF3R		
		7° L.H. Lead Angle	DGI40BU3L	DGI40BC3L	DGI40BD3L	DGI40BE3L	DGI40BF3L		
		.197" (5mm)	Use in all 5mm 'DGP'	Sharp Corner	DGI50BU1	DGI50BC1	DGI50BD1	DGI50BE1	DGI50BF1
				.004" (.10mm) radius	DGI50BU2010	DGI50BC2010	DGI50BD2010	DGI50BE2010	DGI50BF2010
				.008" (.20mm) radius	DGI50BU2020	DGI50BC2020	DGI50BD2020	DGI50BE2020	DGI50BF2020
.010" (.25mm) radius	DGI50BU2025			DGI50BC2025	DGI50BD2025	DGI50BE2025	DGI50BF2025		
.015" (.38mm) radius	DGI50BU			DGI50BC	DGI50BD	DGI50BE	DGI50BF		
.020" (.50mm) radius	DGI50BU2050			DGI50BC2050	DGI50BD2050	DGI50BE2050	DGI50BF2050		
.030" (.75mm) radius	DGI50BU2075			DGI50BC2075	DGI50BD2075	DGI50BE2075	DGI50BF2075		
.040" (1.0mm) radius	DGI50BU2100			DGI50BC2100	DGI50BD2100	DGI50BE2100	DGI50BF2100		
Full Radius	DGI50BU4			DGI50BC4	DGI50BD4	DGI50BE4	DGI50BF4		
15° (+) Top Rake	DGI50BU7P			DGI50BC7P	DGI50BD7P	DGI50BE7P	DGI50BF7P		
15° (-) Top Rake	DGI50BU7N			DGI50BC7N	DGI50BD7N	DGI50BE7N	DGI50BF7N		
7° R.H. Lead Angle	DGI50BU3R			DGI50BC3R	DGI50BD3R	DGI50BE3R	DGI50BF3R		
7° L.H. Lead Angle	DGI50BU3L			DGI50BC3L	DGI50BD3L	DGI50BE3L	DGI50BF3L		
.236" (6mm)	Use in all 6mm 'DGP'			Sharp Corner	DGI60BU1	DGI60BC1	DGI60BD1	DGI60BE1	DGI60BF1
		.004" (.10mm) radius	DGI60BU2010	DGI60BC2010	DGI60BD2010	DGI60BE2010	DGI60BF2010		
		.008" (.20mm) radius	DGI60BU2020	DGI60BC2020	DGI60BD2020	DGI60BE2020	DGI60BF2020		
		.010" (.25mm) radius	DGI60BU2025	DGI60BC2025	DGI60BD2025	DGI60BE2025	DGI60BF2025		
		.015" (.38mm) radius	DGI60BU	DGI60BC	DGI60BD	DGI60BE	DGI60BF		
		.020" (.50mm) radius	DGI60BU2050	DGI60BC2050	DGI60BD2050	DGI60BE2050	DGI60BF2050		
		.030" (.75mm) radius	DGI60BU2075	DGI60BC2075	DGI60BD2075	DGI60BE2075	DGI60BF2075		
		.040" (1.0mm) radius	DGI60BU2100	DGI60BC2100	DGI60BD2100	DGI60BE2100	DGI60BF2100		
		Full Radius	DGI60BU4	DGI60BC4	DGI60BD4	DGI60BE4	DGI60BF4		
		15° (+) Top Rake	DGI60BU7P	DGI60BC7P	DGI60BD7P	DGI60BE7P	DGI60BF7P		
		15° (-) Top Rake	DGI60BU7N	DGI60BC7N	DGI60BD7N	DGI60BE7N	DGI60BF7N		
		7° R.H. Lead Angle	DGI60BU3R	DGI60BC3R	DGI60BD3R	DGI60BE3R	DGI60BF3R		
		7° L.H. Lead Angle	DGI60BU3L	DGI60BC3L	DGI60BD3L	DGI60BE3L	DGI60BF3L		

DGI STYLE  
OD/ID & FACE GROOVING  
INSERTS

## PRODUCT INFORMATION

- External grooving and parting with depth of cut to 1".
- Shank sizes 3/4", 1", 16mm, 20mm and 25mm in straight and 90° orientations.
- Modular tooling system will also accept face grooving heads. See compatibility guide on Page 9-8.
- If round shanks are required, see Page 7-13, Package Styles 'Q' and 'R'.
- Modifications can be provided on any of our tooling. Please contact us with your application requirements.

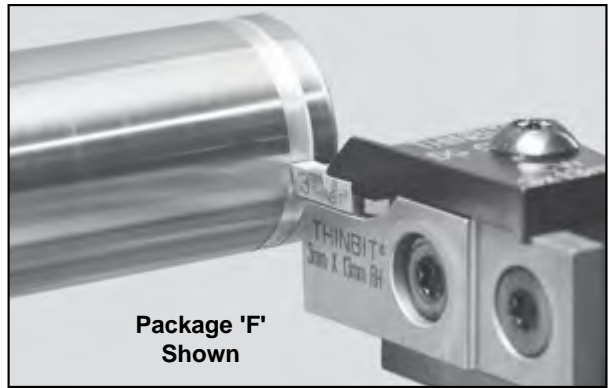

## INSERT SELECTIONS

SEE PAGE 6-1

### INSERT STYLES

#### CORNER RADIUS (TOP VIEW)



#### SHARP CORNER (TOP VIEW)



## TECHNICAL SECTIONS

### PRODUCT DEMONSTRATION



[www.thinbit.com/qr1-13](http://www.thinbit.com/qr1-13)

### SPEEDS AND FEEDS

PG 9-10

### APPLICATION REFERENCE

PG 9-3

### TROUBLESHOOTING

PG 9-7

## PACKAGE STYLE

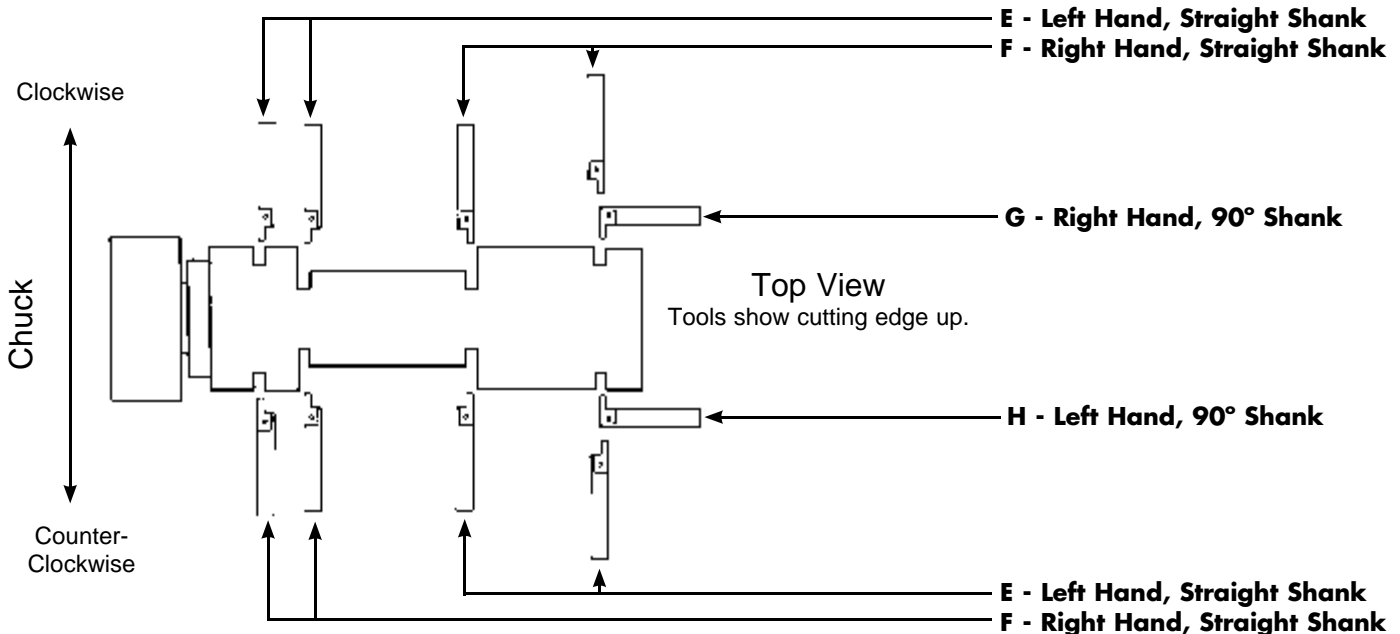

Note: If round shanks are required, see Page 7-13, Package Styles 'Q' and 'R'.

## KAISER TOOL COMPANY, INC.

Phone: 888-THINBIT (888-844-6248) or (260) 484-3620 • Fax: 888-THINFAX (888-844-6329) or (260) 482-1881  
[www.thinbit.com](http://www.thinbit.com) • General E-mail: [thinbit@kaisertool.com](mailto:thinbit@kaisertool.com) • Orders: [orders@thinbit.com](mailto:orders@thinbit.com) • Quotes: [quotes@thinbit.com](mailto:quotes@thinbit.com)

# O.D. GROOVING AND PARTING TOOLS

## ORDERING INSTRUCTIONS

### 3/4" and 1" Shanks

Select the **ORDER CODE** in the table below that represents your selection of tool specifications.

**EXAMPLE:**

The **ORDER CODE** for a 3mm insert width, toolholder package style 'E' with a .500" depth of cut and 1" shank is:

**DGPE301301**

### Metric Shanks

Complete the **ORDER CODE** in the table below with the shank size as 16 (16mm), 20 (20mm) or 25 (25mm).

**EXAMPLE:**

The **ORDER CODE** for a 3mm insert width, toolholder package style 'E' with a .500" depth of cut and 20mm shank is:

**DGPE3013 20** ← Specify the 'SHANK SIZE'

**O.D. GROOVING & PARTING**

SPECIFICATIONS			ORDER CODE										
Insert Width	Depth of Cut	Package Style  See Page 1-13	Toolholder Package <small>Includes Shank, Head, Clamp and Hardware</small>			Inserts  Use Inserts Beginning With	Head	Replacement Parts					
			3/4" Shank <small>3/4"x3/4"x5"</small>	1" Shank <small>1"x1"x5"</small>	Metric Shanks <small>16 = 16x16x125mm 20 = 20x1"x125mm 25 = 25x1"x125mm</small>			Head Hardware	Shanks <small>34 = 3/4" 01 = 1" 16 = 16mm 20 = 20mm 25 = 25mm</small>	Clamp	Clamp Hardware		
2mm (.078")	13mm (1/2")	E	DGPE201334	DGPE201301	DGPE2013 __	'DGI2'  (Page 6-1)	DGH22013	Screw: 2 each S7552	DGS__XL	DGC22013	Screw: S6552		
		G	DGPG201334	DGPG201301	DGPG2013 __		DGH12013		DGS__YR	DGC12013			
		F	DGPF201334	DGPF201301	DGPF2013 __				DGS__XR				
		H	DGPH201334	DGPH201301	DGPH2013 __				DGS__YL				
3mm (.118")	13mm (1/2")	E	DGPE301334	DGPE301301	DGPE3013 __	'DGI3'  (Page 6-1)	DGH23013			DGS__XL		DGC23013	
		G	DGPG301334	DGPG301301	DGPG3013 __		DGH13013		DGS__YR	DGC13013			
		F	DGPF301334	DGPF301301	DGPF3013 __				DGS__XR				
		H	DGPH301334	DGPH301301	DGPH3013 __				DGS__YL				
4mm (.157")	13mm (1/2")	E	DGPE401334	DGPE401301	DGPE4013 __	'DGI4'  (Page 6-1)	DGH24013			DGS__XL		DGC24013	
		G	DGPG401334	DGPG401301	DGPG4013 __		DGH14013		DGS__YR	DGC14013			
		F	DGPF401334	DGPF401301	DGPF4013 __				DGS__XR				
		H	DGPH401334	DGPH401301	DGPH4013 __				DGS__YL				
	20mm (3/4")	E	DGPE402034	DGPE402001	DGPE4020 __		DGH24020		DGS__XL	DGC24020			
		G	DGPG402034	DGPG402001	DGPG4020 __		DGH14020		DGS__YR	DGC14020			
		F	DGPF402034	DGPF402001	DGPF4020 __				DGS__XR				
		H	DGPH402034	DGPH402001	DGPH4020 __				DGS__YL				
5mm (.197")	13mm (1/2")	E	DGPE501334	DGPE501301	DGPE5013 __	'DGI5'  (Page 6-1)	DGH25013	Wrench: W4025	DGS__XL	DGC25013	Wrench: W4025		
		G	DGPG501334	DGPG501301	DGPG5013 __		DGH15013		DGS__YR	DGC15013			
		F	DGPF501334	DGPF501301	DGPF5013 __				DGS__XR				
		H	DGPH501334	DGPH501301	DGPH5013 __				DGS__YL				
	25mm (1")	E	DGPE502534	DGPE502501	DGPE5025 __		DGH25025			DGS__XL		DGC25025	
		G	DGPG502534	DGPG502501	DGPG5025 __		DGH15025			DGS__YR		DGC15025	
		F	DGPF502534	DGPF502501	DGPF5025 __					DGS__XR			
		H	DGPH502534	DGPH502501	DGPH5025 __					DGS__YL			
6mm (.236")	13mm (1/2")	E	DGPE601334	DGPE601301	DGPE6013 __	'DGI6'  (Page 6-1)	DGH26013			DGS__XL		DGC26013	
		G	DGPG601334	DGPG601301	DGPG6013 __		DGH16013		DGS__YR	DGC16013			
		F	DGPF601334	DGPF601301	DGPF6013 __				DGS__XR				
		H	DGPH601334	DGPH601301	DGPH6013 __				DGS__YL				
	25mm (1")	E	DGPE602534	DGPE602501	DGPE6025 __		DGH26025		DGS__XL	DGC26025			
		G	DGPG602534	DGPG602501	DGPG6025 __		DGH16025		DGS__YR	DGC16025			
		F	DGPF602534	DGPF602501	DGPF6025 __				DGS__XR				
		H	DGPH602534	DGPH602501	DGPH6025 __				DGS__YL				

## KAISER TOOL COMPANY, INC.

Phone: 888-THINBIT (888-844-6248) or (260) 484-3620 • Fax: 888-THINFAX (888-844-6329) or (260) 482-1881  
 www.thinbit.com • General E-mail: thinbit@kaisertool.com • Orders: orders@thinbit.com • Quotes: quotes@thinbit.com

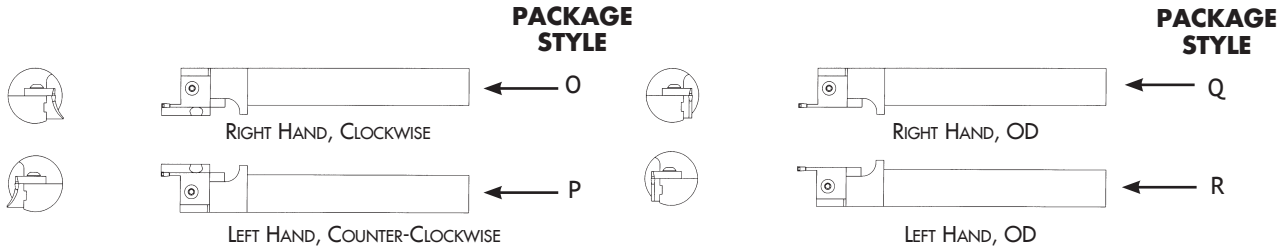

SPECIFICATIONS				ORDER CODE											
Insert Width	Depth of Cut	Package Style	Inserts Page 6-1 Use Inserts Beginning With	Toolholder Package Includes Shank, Head, Clamp and Hardware		Inserts Use Inserts Beginning With	Replacement Parts								
				3/4" Shank 3/4"Ø x 7"	1" Shank 1"Ø x 7"		Head	Head Hardware	Shank 3/4" = 3/4" 01 = 1"	Clamp	Clamp Hardware				
2mm (.078")	13mm (1/2")	O	'DGI2'	DGPO201334__	DGPO201301__	'DGI2'  (Page 6-1)	DGH32013__	Screw: 2 each S7552	DGS__ZR	DGC12013	Screw: S6552  Wrench: W4025				
		Q*		DGPQ201334	DGPQ201301		DGH12013		DGS__ZL	DGC22013					
		P		DGPP201334__	DGPP201301__		DGH42013__		DGS__ZR	DGC13013					
		R*		DGPR201334	DGPR201301		DGH22013		DGS__ZL	DGC23013					
3mm (.118")	13mm (1/2")	O	Use 'DGM13' for major diameter codes '02' & '25' 'DGI3' for all others	DGPO301334__	DGPO301301__	Use 'DGM13' for major diameter codes '02' & '25' 'DGI3' for all others  (Page 6-1)	DGH33013__		Screw: 2 each S7552	DGS__ZR		DGC13013	Screw: S6552  Wrench: W4025		
		Q+		DGPQ301334	DGPQ301301		DGH13013			DGS__ZL		DGC23013			
		P		DGPP301334__	DGPP301301__		DGH43013__			DGS__ZR		DGC14013			
		R+		DGPR301334	DGPR301301		DGH23013			DGS__ZL		DGC24013			
4mm (.157")	13mm (1/2")	O	Use 'DGM14' for major diameter codes '02' & '25' 'DGI4' for all others	DGPO401334__	DGPO401301__	Use 'DGM14' for major diameter codes '02' & '25' 'DGI4' for all others  (Page 6-1)	DGH34013__			Screw: 2 each S7552		DGS__ZR		DGC14013	Screw: S6552  Wrench: W4025
		Q*		DGPQ401334	DGPQ401301		DGH14013					DGS__ZL		DGC24013	
		P		DGPP401334__	DGPP401301__		DGH44013__					DGS__ZR		DGC14020	
		R*		DGPR401334	DGPR401301		DGH23013					DGS__ZL		DGC24020	
	20mm (3/4")	O		DGPO402034__	DGPO402001__		DGH34020__	DGS__ZR			DGC14020				
		Q*		DGPQ402034	DGPQ402001		DGH14020	DGS__ZL			DGC24020				
5mm (.197")	13mm (1/2")	O	'DGI5'	DGPO501334__	DGPO501301__	(Page 6-1)	DGH35013__	Wrench: W4025			DGS__ZR	DGC15013		Wrench: W4025	
		Q*		DGPQ501334	DGPQ501301		DGH15013				DGS__ZL	DGC25013			
		P		DGPP501334__	DGPP501301__		DGH45013__		DGS__ZR		DGC15025				
		R*		DGPR501334	DGPR501301		DGH25013		DGS__ZL		DGC25025				
	25mm (1")	O		DGPO502534__	DGPO502501__		DGH35025__		DGS__ZR		DGC15025				
		Q*		DGPQ502534	DGPQ502501		DGH15025		DGS__ZL		DGC25025				
		P		DGPP502534__	DGPP502501__		DGH45025__		DGS__ZR	DGC16013					
		R*		DGPR502534	DGPR502501		DGH25025		DGS__ZL	DGC26013					
6mm (.236")	13mm (1/2")	O	'DGI6'	DGPO601334__	DGPO601301__	(Page 6-1)	DGH36013__		Wrench: W4025	DGS__ZR	DGC16013	Wrench: W4025			
		Q*		DGPQ601334	DGPQ601301		DGH16013			DGS__ZL	DGC26013				
		P		DGPP601334__	DGPP601301__		DGH46013__			DGS__ZR	DGC16025				
		R*		DGPR601334	DGPR601301		DGH26013			DGS__ZL	DGC26025				
	25mm (1")	O		DGPO602534__	DGPO602501__		DGH36025__	DGS__ZR		DGC16025					
		Q*		DGPQ602534	DGPQ602501		DGH16025	DGS__ZL		DGC26025					
		P		DGPP602534__	DGPP602501__		DGH46025__	DGS__ZR		DGC16025					
		R*		DGPR602534	DGPR602501		DGH26025	DGS__ZL		DGC26025					

\* Codes not required on Q and R packages

Major Diameter Range	Insert Width	Code	Insert Style	Major Diameter Range	Insert Width	Code	Insert Style	
.787"-.885" (20-22.5mm)	2mm	02	DGI	1.377"-1.574" (35-40mm)	2mm	50	DGI	
	3 & 4mm	02	DGMI		3, 4, 5 & 6mm	34	DGI	
.885"-.984" (22.5-25mm)	2mm	25	DGI		1.574"-1.968" (40-50mm)		45	DGI
	3 & 4mm	25	DGMI		1.968"-2.362" (50-60mm)		56	DGI
.984"-1.082" (25-27.5mm)	2mm	57	DGI		2.362"-2.952" (60-75mm)	All	67	DGI
	3, 4, 5 & 6mm	23	DGI		2.952"-3.937" (75-100mm)		71	DGI
1.082"-1.181" (27.5-30mm)	2mm	70	DGI		3.937"-5.905" (100-150mm)		11	DGI
	3, 4, 5 & 6mm	23	DGI		5.905"-11.811" (150-300mm)		13	DGI
1.181"-1.377" (30-35mm)	2mm	05	DGI		11.811" - ∞ (300mm-∞)		30	DGI
	3, 4, 5 & 6mm	34	DGI					

Note:  
As long as first plunge is made within major diameter range and each following plunge overlaps, groove width can be increased toward or away from center of part.

# DEEPGROOVE<sup>®</sup> SQUARE METRS WITH INTERNAL FACE GROOVING HEADS

U.S. PATENT NO. 5,638,728

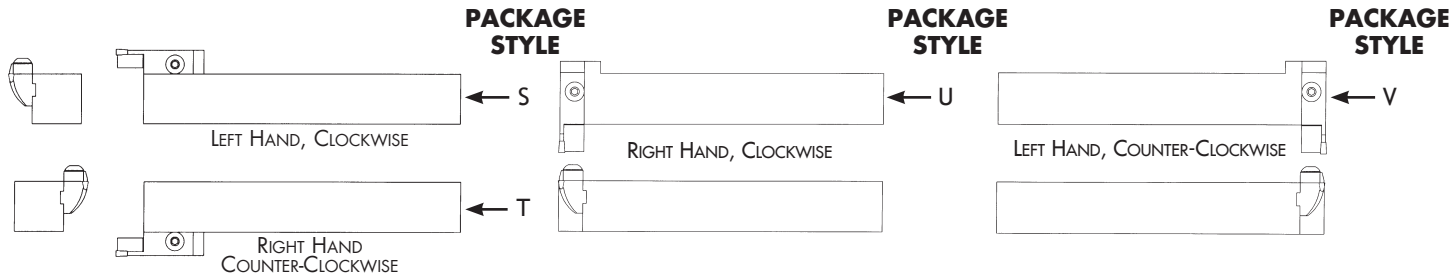

SPECIFICATIONS			ORDER CODE												
Insert Width	Depth of Cut	Package Style See Above	Toolholder Package Includes Shank, Head, Clamp and Hardware			Inserts Use Inserts Beginning With	Replacement Parts								
			3/4" Shank 3/4"x3/4"x5"	1" Shank 1"x1"x5"	Metric Shanks 16 = 16x16x125mm 20 = 20x1"x125mm 25 = 25x1"x125mm		Head	Head Hardware	Shank 34 = 3/4" 01 = 1" 16 = 16mm 20 = 20mm 25 = 25mm	Clamp	Clamp Hardware				
2mm (.078")	13mm (1/2")	S	DGPS201334_	DGPS201301_	DGPS2013_	'DGI2'  (Page 6-1)	DGH52013_	DGH62013_	DGS_ XL	DGC52013	DGS_ YR	DGS_ XR	DGS_ YL	DGC62013	
		U	DGPU201334_	DGPU201301_	DGPU2013_										
		T	DGPT201334_	DGPT201301_	DGPT2013_										
		V	DGPV201334_	DGPV201301_	DGPV2013_										
3mm (.118")	13mm (1/2")	S	DGPS301334_	DGPS301301_	DGPS3013_	'DGI3'  (Page 6-1)	DGH53013_	DGH63013_	DGS_ XL	DGC53013	DGS_ YR	DGS_ XR	DGS_ YL	DGC63013	
		U	DGPU301334_	DGPU301301_	DGPU3013_										
		T	DGPT301334_	DGPT301301_	DGPT3013_										
		V	DGPV301334_	DGPV301301_	DGPV3013_										
4mm (.157")	13mm (1/2")	S	DGPS401334_	DGPS401301_	DGPS4013_	'DGI4'  (Page 6-1)	DGH54013_	DGH64013_	DGS_ XL	DGC54013	DGS_ YR	DGS_ XR	DGS_ YL	DGC64013	
		U	DGPU401334_	DGPU401301_	DGPU4013_										
		T	DGPT401334_	DGPT401301_	DGPT4013_										
		V	DGPV401334_	DGPV401301_	DGPV4013_										
	20mm (3/4")	S	DGPS402034_	DGPS402001_	DGPS4020_		DGH54020_	DGH64020_	DGS_ XL	DGC54020	DGS_ YR	DGS_ XR	DGS_ YL	DGC64020	Screw: 2 each S7552
		U	DGPU402034_	DGPU402001_	DGPU4020_										
5mm (.197")	13mm (1/2")	S	DGPS501334_	DGPS501301_	DGPS5013_	'DGI5'  (Page 6-1)	DGH55013_	DGH65013_	DGS_ XL	DGC55013	DGS_ YR	DGS_ XR	DGS_ YL	DGC65013	Wrench: W4025
		U	DGPU501334_	DGPU501301_	DGPU5013_										
		T	DGPT501334_	DGPT501301_	DGPT5013_										
		V	DGPV501334_	DGPV501301_	DGPV5013_										
	25mm (1")	S	DGPS502534_	DGPS502501_	DGPS5025_		DGH55025_	DGH65025_	DGS_ XL	DGC55025	DGS_ YR	DGS_ XR	DGS_ YL	DGC65025	
		U	DGPU502534_	DGPU502501_	DGPU5025_										
6mm (.236")	13mm (1/2")	S	DGPS601334_	DGPS601301_	DGPS6013_	'DGI6'  (Page 6-1)	DGH56013_	DGH66013_	DGS_ XL	DGC56013	DGS_ YR	DGS_ XR	DGS_ YL	DGC66013	
		U	DGPU601334_	DGPU601301_	DGPU6013_										
		T	DGPT601334_	DGPT601301_	DGPT6013_										
		V	DGPV601334_	DGPV601301_	DGPV6013_										
	25mm (1")	S	DGPS602534_	DGPS602501_	DGPS6025_		DGH56025_	DGH66025_	DGS_ XL	DGC56025	DGS_ YR	DGS_ XR	DGS_ YL	DGC66025	
		U	DGPU602534_	DGPU602501_	DGPU6025_										
		T	DGPT602534_	DGPT602501_	DGPT6025_										
		V	DGPV602534_	DGPV602501_	DGPV6025_										



Major Diameter Range	Code
1.574"-1.968" (40-50mm)	45
1.968"-2.362" (50-60mm)	56
2.362"-2.952" (60-75mm)	67
2.952"-3.937" (75-100mm)	71
3.937"-5.905" (100-150mm)	11
5.905"-11.811" (150-300mm)	13
11.811"-∞ (300mm-∞)	30

**Note:**  
As long as first plunge is made within major diameter range and each following plunge overlaps, groove width can be increased toward or away from center of part.

DEEPGROOVE<sup>®</sup>  
ALTERNATE PKGS