

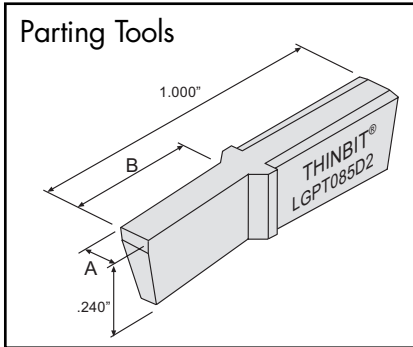

# introducing

## GROOVE 'N TURN<sup>®</sup>



FRONT RAKE: Primary 21°  
 SIDE CLEARANCE: 10° Lead side  
 BACK CLEARANCE: 30° Lead side  
 BACK CLEARANCE: 5° Trailing side

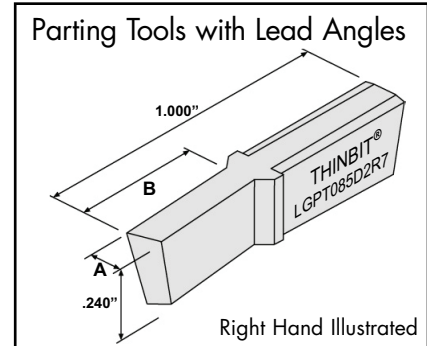

SPECIFICATIONS				ORDER CODE			INFO.				
Insert Width	Depth of Cut	Length	Lead Angle and Orientation	Insert Grades See Page 9-5 for expanded material descriptions and Page 9-20 for speeds and feeds information			Coatings See Page 9-6 for expanded coating descriptions Use uncoated part number and add coating code				Toolholder Catalog section 7 Use toolholders beginning with
'A'	'B'	'C'	'D'	DURA-MAX <sup>®</sup> 2000 Carbide For Steel & Interrupted Cutting	DURA-MAX <sup>®</sup> 5000 Carbide For Aluminum & Non-ferrous	High Speed Steel	TiN	TiCN	TiAlN	Diamond	"L" Use any straight holder or 90° holder
±.001	Minimum	Overall									
.025"	.200"	.800"	0° Centered	LGPT025D2	LGPT025D5	LGPT025HS					
.025"	.200"	.800"	7° Right Hand	LGPT025D27R	LGPT025D57R	LGPT025HS7R					
.025"	.200"	.800"	7° Left Hand	LGPT025D27L	LGPT025D57L	LGPT025HS7L					
.045"	.500"	1.00"	0° Centered	LGPT045D2	LGPT045D5	LGPT045HS					
.045"	.500"	1.00"	7° Right Hand	LGPT045D27R	LGPT045D57R	LGPT045HS7R					
.045"	.500"	1.00"	7° Left Hand	LGPT045D27L	LGPT045D57L	LGPT045HS7L					
.062"	.500"	1.00"	0° Centered	LGPT062D2	LGPT062D5	LGPT062HS					
.062"	.500"	1.00"	7° Right Hand	LGPT062D27R	LGPT062D57R	LGPT062HS7R	add 'C'	add 'D'	add 'E'	add 'F'	
.062"	.500"	1.00"	7° Left Hand	LGPT062D27L	LGPT062D57L	LGPT062HS7L					
.085"	.500"	1.00"	0° Centered	LGPT085D2	LGPT085D5	LGPT085HS					
.085"	.500"	1.00"	7° Right Hand	LGPT085D27R	LGPT085D57R	LGPT085HS7R					
.085"	.500"	1.00"	7° Left Hand	LGPT085D27L	LGPT085D57L	LGPT085HS7L					
.115"	.500"	1.00"	0° Centered	LGPT115D2	LGPT115D5	LGPT115HS					
.115"	.500"	1.00"	7° Right Hand	LGPT115D27R	LGPT115D57R	LGPT115HS7R					
.115"	.500"	1.00"	7° Left Hand	LGPT115D27L	LGPT115D57L	LGPT115HS7L					